

Name:

Section:

Physics 208 Quiz 5

March 03, 2008 (due March 07, 2008)

Problem 1 (40 Points)

- (a) Three capacitors are hooked to an ideal battery with voltage V as shown in the figure. Calculate the total capacitance of this circuit.
- (b) How much charge is stored on the (positively charged) upper plates of each capacitor and how much in total?
- (c) How much energy is stored in each capacitor and how much in total?

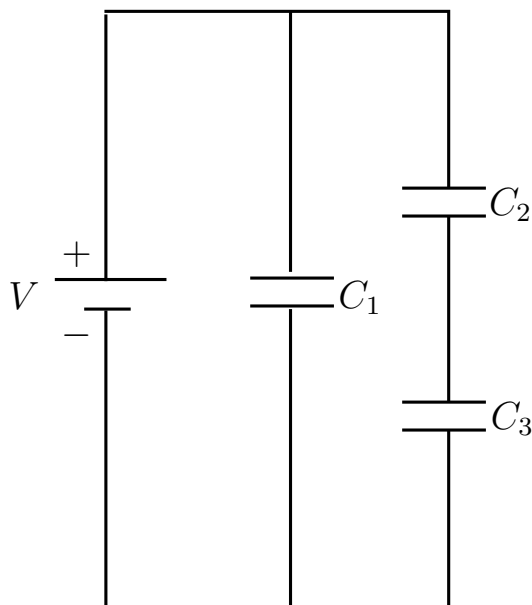

see problem 2 on next page!

Problem 2 (60 Points)

- (a) For the network given in the circuit diagram below, calculate the currents through each resistor and the voltage at the capacitor. [Hint: Express all results in terms of the quantities given in the circuit diagram!]
- (b) Suppose, you only need to know the voltage at the capacitor. How can you simplify the task to find it, compared to the complete network analysis, you have done in part (a)? Compare the results!
- (c) What is the total power used by this circuit?
- (d) How much energy is stored in the capacitor?

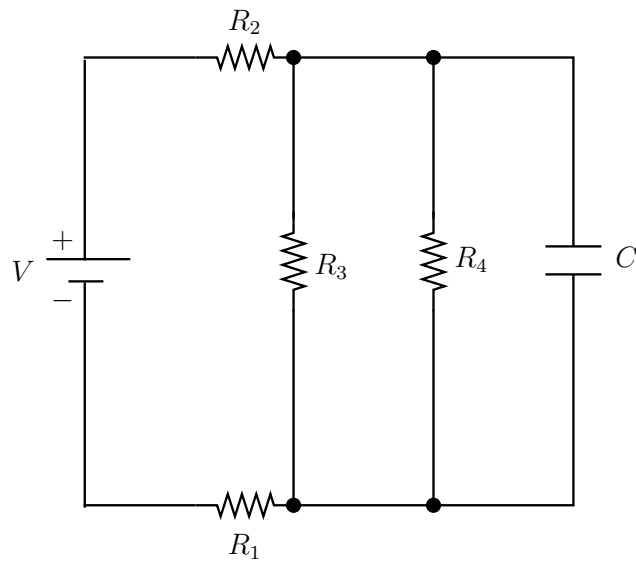

hint: Label all your currents and voltages at resistors and capacitors clearly, including the usual signs for directions!